

# Standard Top KSSU Series - Sandwich/Salad Prep Tables

## KSSU27-6/2

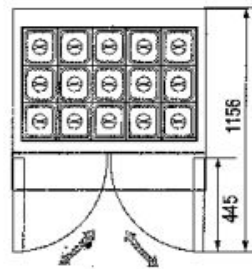
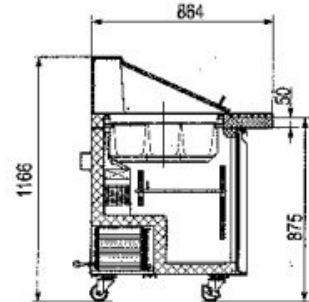
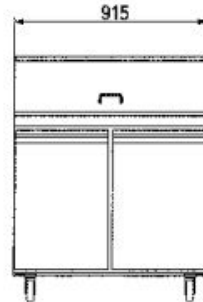

Doors	Shelves	Dimensions - LxWxD mm / in	Capacity	HP	AMPS	Voltage	Plug Type
1	1	1075 / 42 3/8" 750 / 27 1/2" 698 / 29 1/2"	5.7ft	1/5	2.88	115/60/1	NEMA 5-15P

- Stainless steel interior and exterior sides, aluminum back.
- Refrigeration system keeps food at safe temperatures between 0.5°C to 5°C
- Features a self-closing and stay-open locking door
- Includes 3 epoxy coated shelves with 90 lb. capacity each
- Digital temperature controller with automatic defrost function
- Cutting board variable between removable and riveted
- Preinstalled heavy duty casters with brakes
- Eco-friendly & efficient Hydro-Carbon R290 refrigerant



# Standard Top KSSU Series - Sandwich/Salad Prep Tables

## KSSU36-10

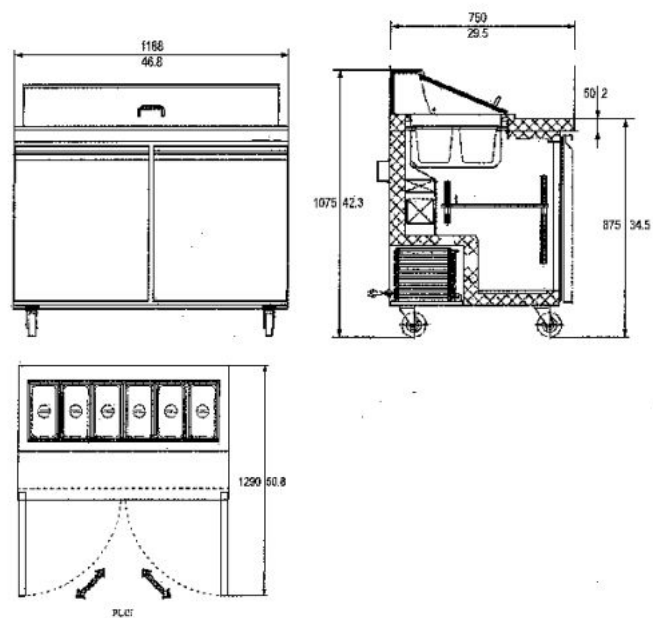

Doors	Shelves	Dimensions - LxWxD mm / in	Capacity	HP	AMPS	Voltage	Plug Type
2	2	1075 / 42 <sup>3</sup> / <sub>8</sub> " 920 / 36 <sup>1</sup> / <sub>4</sub> " 750 / 29 <sup>1</sup> / <sub>2</sub> "	7.6ft	1/5	3.24	115/60/1	NEMA 5-15P

- Stainless steel interior and exterior sides, aluminum back.
- Refrigeration system keeps food at safe temperatures between 0.5°C to 5°C
- Features a self-closing and stay-open locking door
- Includes 3 epoxy coated shelves with 90 lb. capacity each
- Digital temperature controller with automatic defrost function
- Cutting board variable between removable and riveted
- Preinstalled heavy duty casters with brakes
- Eco-friendly & efficient Hydro-Carbon R290 refrigerant



# Standard Top KSSU Series - Sandwich/Salad Prep Tables

## KSSU48-12

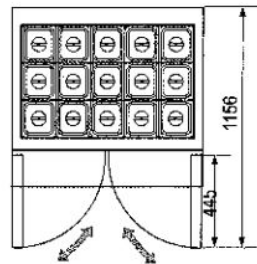
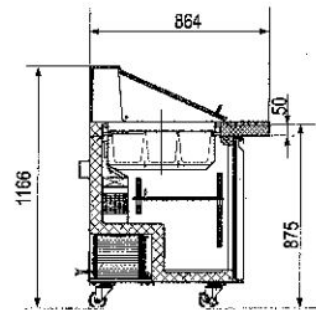
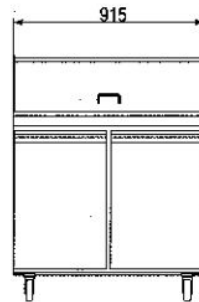

Doors	Shelves	Dimensions - LxWxD mm / in	Capacity	HP	AMPS	Voltage	Plug Type
2	2	1075 / 42 <sup>3</sup> / <sub>8</sub> " 1188 / 46 <sup>7</sup> / <sub>8</sub> " 750 / 29 <sup>1</sup> / <sub>2</sub> "	9.5ft	¼+	4.56	115/60/1	NEMA 5-15P

- Stainless steel interior and exterior sides, aluminum back.
- Refrigeration system keeps food at safe temperatures between 0.5°C to 5°C
- Features a self-closing and stay-open locking door
- Includes 3 epoxy coated shelves with 90 lb. capacity each
- Digital temperature controller with automatic defrost function
- Cutting board variable between removable and riveted
- Preinstalled heavy duty casters with brakes
- Eco-friendly & efficient Hydro-Carbon R290 refrigerant



# Standard Top KSSU Series - Sandwich/Salad Prep Tables

## KSSU60-16

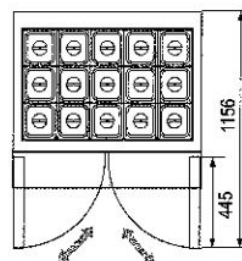
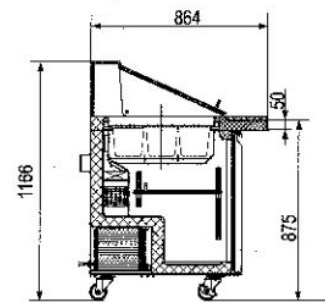
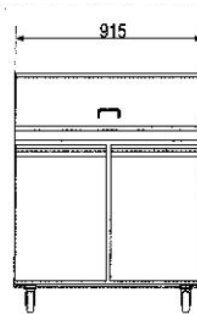

Doors	Shelves	Dimensions - LxWxD mm / in	Capacity	HP	AMPS	Voltage	Plug Type
2	2	1075 / 42 <sup>3</sup> / <sub>8</sub> " 1529 / 60 <sup>1</sup> / <sub>8</sub> " 750 / 29 <sup>1</sup> / <sub>2</sub> "	15ft	¼+	4.8	115/60/1	NEMA 5-15P

- Stainless steel interior and exterior sides, aluminum back.
- Refrigeration system keeps food at safe temperatures between 0.5°C to 5°C
- Features a self-closing and stay-open locking door
- Includes 3 epoxy coated shelves with 90 lb. capacity each
- Digital temperature controller with automatic defrost function
- Cutting board variable between removable and riveted
- Preinstalled heavy duty casters with brakes
- Eco-friendly & efficient Hydro-Carbon R290 refrigerant



# Standard Top KSSU Series - Sandwich/Salad Prep Tables

## KSSU72-18

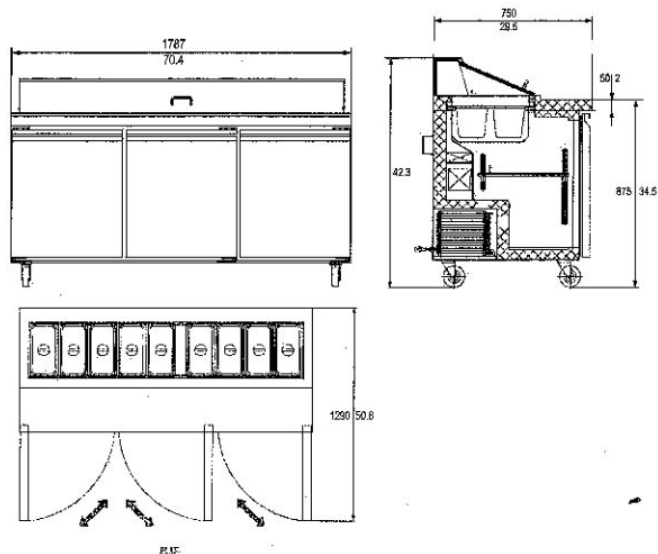

Doors	Shelves	Dimensions - LxWxD mm / in	Capacity	HP	AMPS	Voltage	Plug Type
3	3	1075 / 42 <sup>3</sup> / <sub>8</sub> " 1787 / 70 <sup>2</sup> / <sub>8</sub> " 750 / 29 <sup>1</sup> / <sub>2</sub> "	15.5ft	3/4	8.9	115/60/1	NEMA 5-15P

- Stainless steel interior and exterior sides, aluminum back.
- Refrigeration system keeps food at safe temperatures between 0.5°C to 5°C
- Features a self-closing and stay-open locking door
- Includes 3 epoxy coated shelves with 90 lb. capacity each
- Digital temperature controller with automatic defrost function
- Cutting board variable between removable and riveted
- Preinstalled heavy duty casters with brakes
- Eco-friendly & efficient Hydro-Carbon R290 refrigerant



# Mega Top KSSU Series - Sandwich/Salad Prep Tables

## KSSU27-9/3

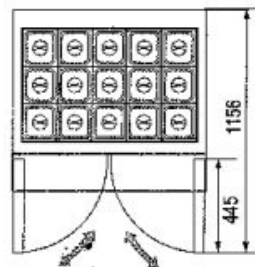
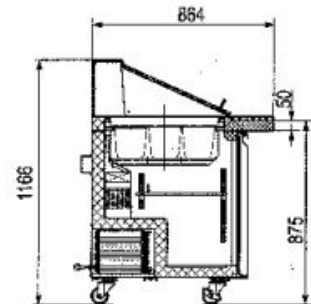
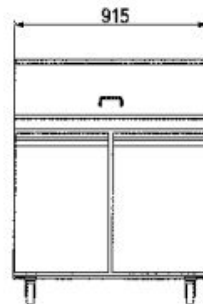

Doors	Shelves	Dimensions - LxWxD mm / in	Capacity	HP	AMPS	Voltage	Plug Type
1	1	1166 / 45 9/10" 698 / 27 1/2" 864 / 34"	5.7ft	1/5	2.88	115/60/1	NEMA 5-15P

- Stainless steel interior and exterior sides, aluminum back.
- Refrigeration system keeps food at safe temperatures between 0.5°C to 5°C
- Features a self-closing and stay-open locking door
- Includes 3 epoxy coated shelves with 90 lb. capacity each
- Digital temperature controller with automatic defrost function
- Cutting board variable between removable and riveted
- Preinstalled heavy duty casters with brakes
- Eco-friendly & efficient Hydro-Carbon R290 refrigerant



# Mega Top KSSU Series - Sandwich/Salad Prep Tables

## KSSU36-15

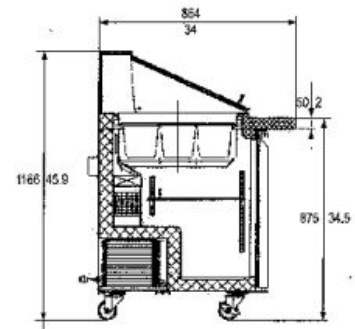
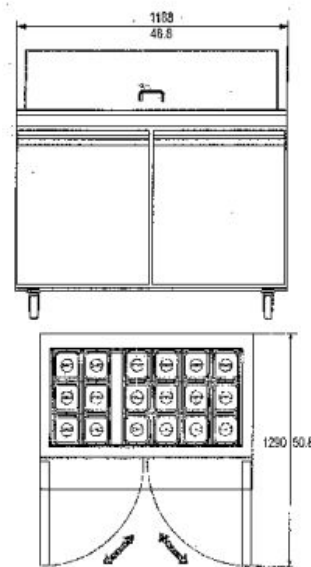

Doors	Shelves	Dimensions - LxWxD mm / in	Capacity	HP	AMPS	Voltage	Plug Type
2	2	1166 / 45 9/10" 920 / 36 1/4" 864 / 34"	7.6ft	1/5	3.24	115/60/1	NEMA 5-15P

- Stainless steel interior and exterior sides, aluminum back.
- Refrigeration system keeps food at safe temperatures between 0.5°C to 5°C
- Features a self-closing and stay-open locking door
- Includes 3 epoxy coated shelves with 90 lb. capacity each
- Digital temperature controller with automatic defrost function
- Cutting board variable between removable and riveted
- Preinstalled heavy duty casters with brakes
- Eco-friendly & efficient Hydro-Carbon R290 refrigerant



# Mega Top KSSU Series - Sandwich/Salad Prep Tables

## KSSU48-18

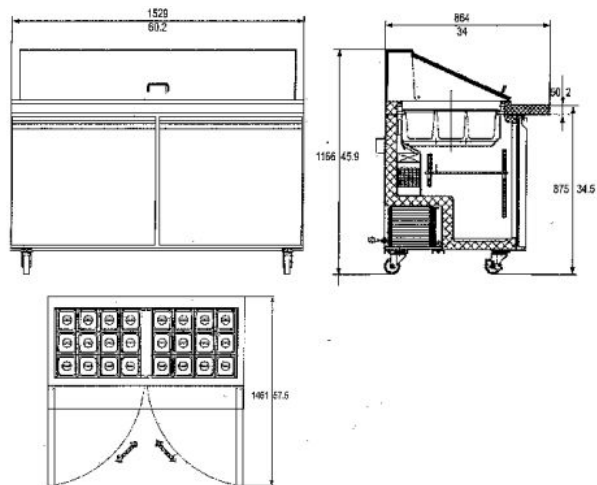

Doors	Shelves	Dimensions - LxWxD mm / in	Capacity	HP	AMPS	Voltage	Plug Type
2	2	1166 / 45 9/10" 1188 / 46 7/8" 864 / 34"	9.5ft	1/4+	4.56	115/60/1	NEMA 5-15P

- Stainless steel interior and exterior sides, aluminum back.
- Refrigeration system keeps food at safe temperatures between 0.5°C to 5°C
- Features a self-closing and stay-open locking door
- Includes 3 epoxy coated shelves with 90 lb. capacity each
- Digital temperature controller with automatic defrost function
- Cutting board variable between removable and riveted
- Preinstalled heavy duty casters with brakes
- Eco-friendly & efficient Hydro-Carbon R290 refrigerant





# Mega Top KSSU Series - Sandwich/Salad Prep Tables

## KSSU60-24

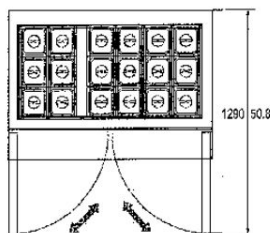
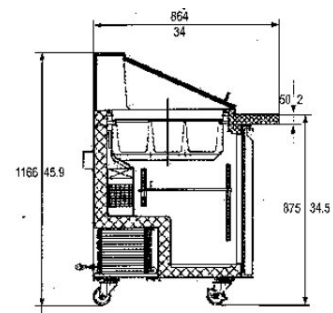
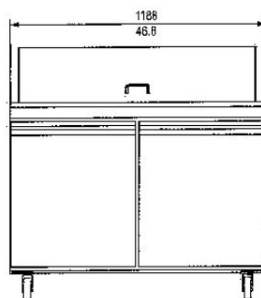

Doors	Shelves	Dimensions - LxWxD mm / in	Capacity	HP	AMPS	Voltage	Plug Type
2	2	1166 / 45 9/10" 1529 / 60 1/8" 750 / 34"	15ft	1/4+	4.8	115/60/1	NEMA 5-15P

- Stainless steel interior and exterior sides, aluminum back.
- Refrigeration system keeps food at safe temperatures between 0.5°C to 5°C
- Features a self-closing and stay-open locking door
- Includes 3 epoxy coated shelves with 90 lb. capacity each
- Digital temperature controller with automatic defrost function
- Cutting board variable between removable and riveted
- Preinstalled heavy duty casters with brakes
- Eco-friendly & efficient Hydro-Carbon R290 refrigerant



# Mega Top KSSU Series - Sandwich/Salad Prep Tables

## KSSU72-30

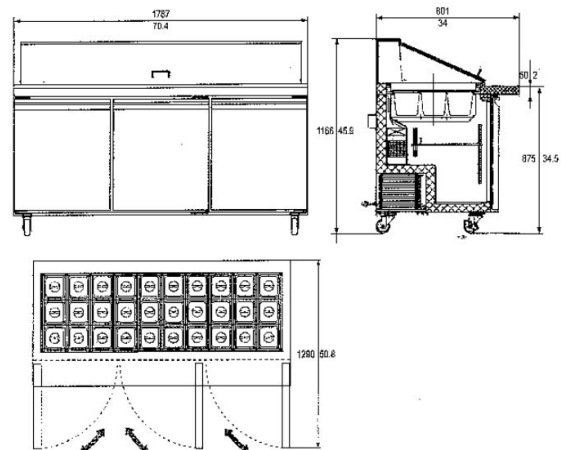

Doors	Shelves	Dimensions - LxWxD mm / in	Capacity	HP	AMPS	Voltage	Plug Type
3	3	1166 / 45 9/10" 1787 / 70 3/4" 864 / 34"	15.5ft	3/4	8.9	115/60/1	NEMA 5-15P

- Stainless steel interior and exterior sides, aluminum back.
- Refrigeration system keeps food at safe temperatures between 0.5°C to 5°C
- Features a self-closing and stay-open locking door
- Includes 3 epoxy coated shelves with 90 lb. capacity each
- Digital temperature controller with automatic defrost function
- Cutting board variable between removable and riveted
- Preinstalled heavy duty casters with brakes
- Eco-friendly & efficient Hydro-Carbon R290 refrigerant



# KPP Series - Pizza Prep Tables

## KPP-49-6

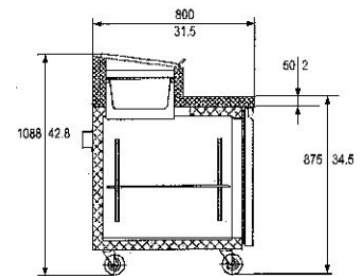
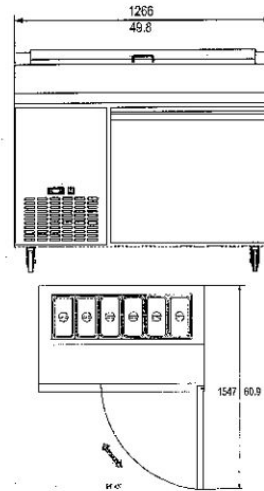

Doors	Shelves	Dimensions - LxWxD mm / in	Capacity	HP	AMPS	Voltage	Plug Type
1	1	1088 / 42 7/8" 1266 / 49 7/8" 800 / 31 1/2"	13.8ft	1/6	2.64	115/60/1	NEMA 5-15P

- Stainless steel interior and exterior sides, aluminum back.
- Refrigeration system keeps food at safe temperatures between 0.5°C to 5°C
- Features a self-closing and stay-open locking door
- Includes 3 epoxy coated shelves with 90 lb. capacity each
- Digital temperature controller with automatic defrost function
- Cutting board variable between removable and riveted
- Preinstalled heavy duty casters with brakes
- Eco-friendly & efficient Hydro-Carbon R290 refrigerant



# KPP Series - Pizza Prep Tables

## KPP72-9

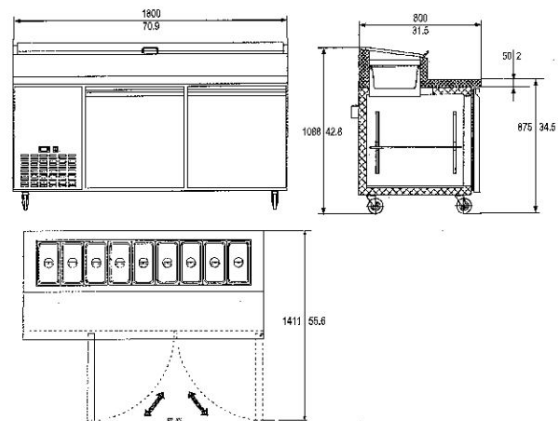

Doors	Shelves	Dimensions - LxWxD mm / in	Capacity	HP	AMPS	Voltage	Plug Type
2	2	1088 / 42 7/8" 1800 / 70 9/10" 800 / 31 1/2"	16.9ft	1/5	3.42	115/60/1	NEMA 5-15P

- Stainless steel interior and exterior sides, aluminum back.
- Refrigeration system keeps food at safe temperatures between 0.5°C to 5°C
- Features a self-closing and stay-open locking door
- Includes 3 epoxy coated shelves with 90 lb. capacity each
- Digital temperature controller with automatic defrost function
- Cutting board variable between removable and riveted
- Preinstalled heavy duty casters with brakes
- Eco-friendly & efficient Hydro-Carbon R290 refrigerant



# KPP Series - Pizza Prep Tables

## KPP93-12

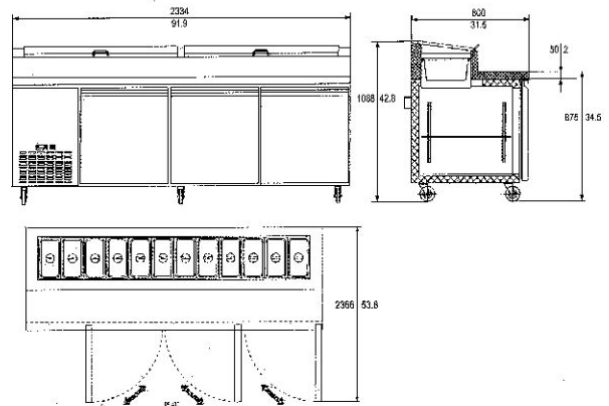

Doors	Shelves	Dimensions - LxWxD mm / in	Capacity	HP	AMPS	Voltage	Plug Type
3	3	1088 / 42" 2334 / 91 9/10" 800 / 31 1/2"	24.2ft	1/4+	5.28	115/60/1	NEMA 5-15P

- Stainless steel interior and exterior sides, aluminum back.
- Refrigeration system keeps food at safe temperatures between 0.5°C to 5°C
- Features a self-closing and stay-open locking door
- Includes 3 epoxy coated shelves with 90 lb. capacity each
- Digital temperature controller with automatic defrost function
- Cutting board variable between removable and riveted
- Preinstalled heavy duty casters with brakes
- Eco-friendly & efficient Hydro-Carbon R290 refrigerant



# KCB Series - Chef Bases

## KCB-36-2

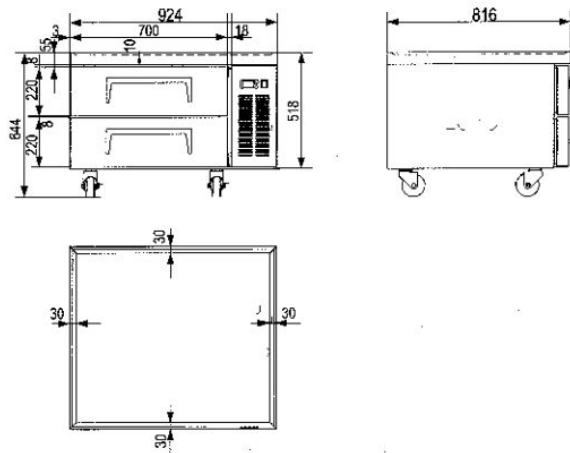

Drawers	GN Pans	Dimensions - LxWxD mm / in	Capacity	HP	AMPS	Voltage	Plug Type
2	2*1/1+6* 1/6	645 / 25 3/8" 924 / 36 3/8" 816 / 32 1/8"	5.9ft	1/6	2.52	115/60/1	NEMA 5-15P

- Stainless steel exterior and interior; foamed-in-place polyurethane insulation
- Stainless steel top with marine edge
- 880 lb. weight capacity
- Each drawer holds 1 full size and (3) 1/6 size food pans, 4" deep
- Heavy duty pull handles
- Maintains temperatures between 0.5°C - 5°C
- Removable installation board for convenient cleaning and service
- Eco-friendly & efficient Hydro-Carbon R290 refrigerant



# KCB Series - Chef Bases

## KCB-52-2

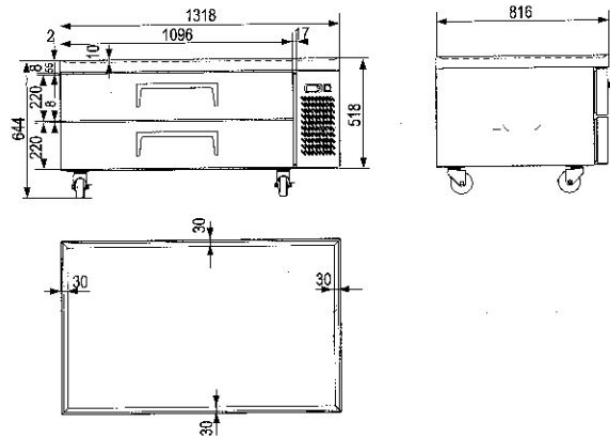

Drawers	GN Pans	Dimensions - LxWxD mm / in	Capacity	HP	AMPS	Voltage	Plug Type
2	6*1/1	645 / 25 3/8" 1318 / 51 7/8" 816 / 32 1/8"	9.9ft	1/6	3.48	115/60/1	NEMA 5-15P

- Stainless steel exterior and interior; foamed-in-place polyurethane insulation
- Stainless steel top with marine edge
- 880 lb. weight capacity
- Each drawer holds 1 full size and (3) 1/6 size food pans, 4" deep
- Heavy duty pull handles
- Maintains temperatures between 0.5°C - 5°C
- Removable installation board for convenient cleaning and service
- Eco-friendly & efficient Hydro-Carbon R290 refrigerant



# KCB Series - Chef Bases

## KCB-72-4

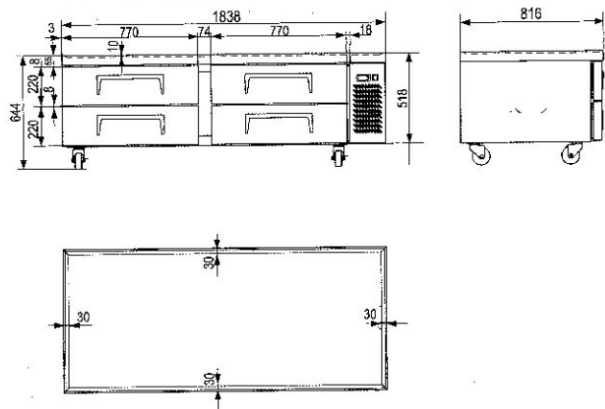

Drawers	GN Pans	Dimensions - LxWxD mm / in	Capacity	HP	AMPS	Voltage	Plug Type
4	8*1/1	645 / 25 5/8" 1839 / 72 3/8" 816 / 32 1/8"	15ft	1/5	4.68	115/60/1	NEMA 5-15P

- Stainless steel exterior and interior; foamed-in-place polyurethane insulation
- Stainless steel top with marine edge
- 880 lb. weight capacity
- Each drawer holds 1 full size and (3) 1/6 size food pans, 4" deep
- Heavy duty pull handles
- Maintains temperatures between 0.5°C - 5°C
- Removable installation board for convenient cleaning and service
- Eco-friendly & efficient Hydro-Carbon R290 refrigerant

