

KUC Series - Undercounter Refrigerators

KUC27-1

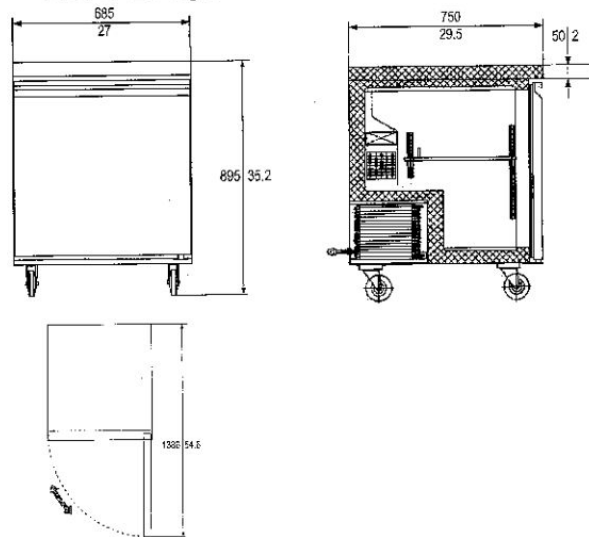

UUC-27R/F-HC



Doors	Shelves	Dimensions - LxWxD mm / in	Capacity	HP	AMPS	Voltage	Plug Type
1	1	895 / 35 1/8" 685 / 27" 750 / 29 1/2"	6.3ft	1/6	1.9	115/60/1	NEMA 5-15P

- Stainless steel interior and exterior sides, aluminum back.
- Refrigeration system keeps food at safe temperatures between 0.5°C to 5°C
- Features a self-closing and stay-open locking door
- Includes 3 epoxy coated shelves with 90 lb. capacity each
- Digital temperature controller with automatic defrost function
- Preinstalled heavy duty casters with brakes
- Eco-friendly & efficient Hydro-Carbon R290 refrigerant



KUC Series - Undercounter Refrigerators

KUC48-2

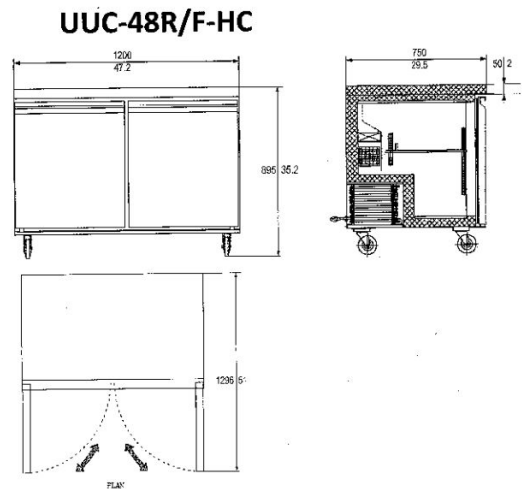

Doors	Shelves	Dimensions - LxWxD mm / in	Capacity	HP	AMPS	Voltage	Plug Type
2	2	895 / 35 1/8" 1200 / 47 1/8" 750 / 29 1/2"	12ft	1/5	2.7	115/60/1	NEMA 5-15P

- Stainless steel interior and exterior sides, aluminum back.
- Refrigeration system keeps food at safe temperatures between 0.5°C to 5°C
- Features a self-closing and stay-open locking door
- Includes 3 epoxy coated shelves with 90 lb. capacity each
- Digital temperature controller with automatic defrost function
- Preinstalled heavy duty casters with brakes
- Eco-friendly & efficient Hydro-Carbon R290 refrigerant



KUC Series - Undercounter Refrigerators

KUC60-2



UUC-60R/F-HC

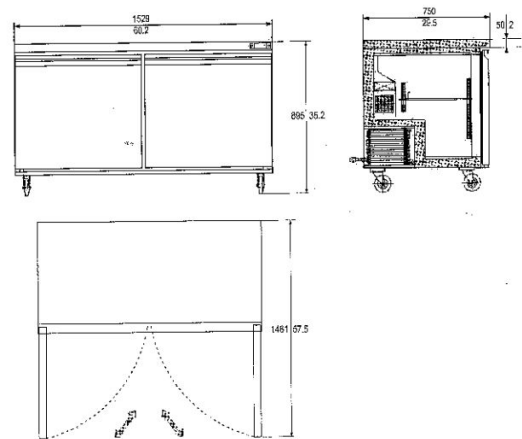

Doors	Shelves	Dimensions - LxWxD mm / in	Capacity	HP	AMPS	Voltage	Plug Type
2	2	895 / 35 1/8" 1526 / 60 1/8" 750 / 29 1/2"	15ft	1/5	2.9	115/60/1	NEMA 5-15P

- Stainless steel interior and exterior sides, aluminum back.
- Refrigeration system keeps food at safe temperatures between 0.5°C to 5°C
- Features a self-closing and stay-open locking door
- Includes 3 epoxy coated shelves with 90 lb. capacity each
- Digital temperature controller with automatic defrost function
- Preinstalled heavy duty casters with brakes
- Eco-friendly & efficient Hydro-Carbon R290 refrigerant



KUC Series - Undercounter Refrigerators

KUC72-3



UUC-72R-HC

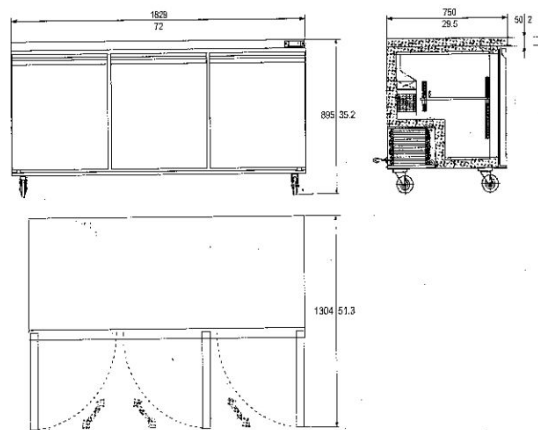

Doors	Shelves	Dimensions - LxWxD mm / in	Capacity	HP	AMPS	Voltage	Plug Type
3	3	895 / 35 1/8" 1829 / 72" 750 / 29 1/2"	15.5ft	1/5	3.2	115/60/1	NEMA 5-15P

- Stainless steel interior and exterior sides, aluminum back.
- Refrigeration system keeps food at safe temperatures between 0.5°C to 5°C
- Features a self-closing and stay-open locking door
- Includes 3 epoxy coated shelves with 90 lb. capacity each
- Digital temperature controller with automatic defrost function
- Preinstalled heavy duty casters with brakes
- Eco-friendly & efficient Hydro-Carbon R290 refrigerant



KUC-F Series - Undercounter Freezers

KUC27-F-1



UUC-27R/F-HC

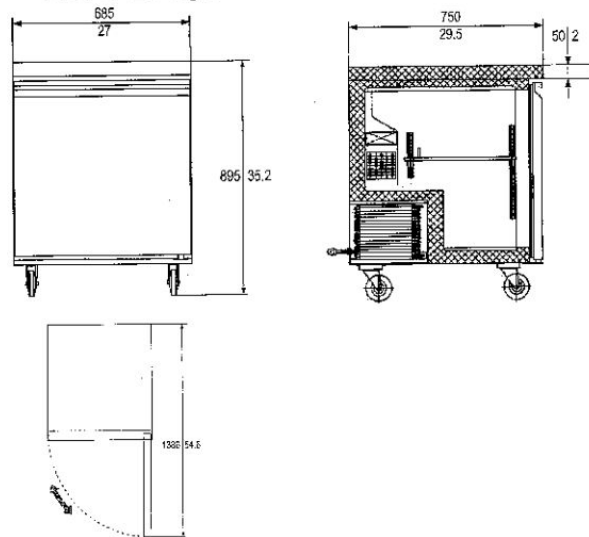

Doors	Shelves	Dimensions - LxWxD mm / in	Capacity	HP	AMPS	Voltage	Plug Type
1	1	895 / 35 1/8" 685 / 27" 750 / 29 1/2"	6.3ft	1/5	2.1	115/60/1	NEMA 5-15P

- Stainless steel interior and exterior sides, aluminum back.
- Refrigeration system keeps food at safe temperatures between -22°C to -18°C
- Features a self-closing and stay-open locking door
- Includes 3 epoxy coated shelves with 90 lb. capacity each
- Digital temperature controller with automatic defrost function
- Preinstalled heavy duty casters with brakes
- Eco-friendly & efficient Hydro-Carbon R290 refrigerant



KUC-F Series - Undercounter Freezers

KUC48-F-2

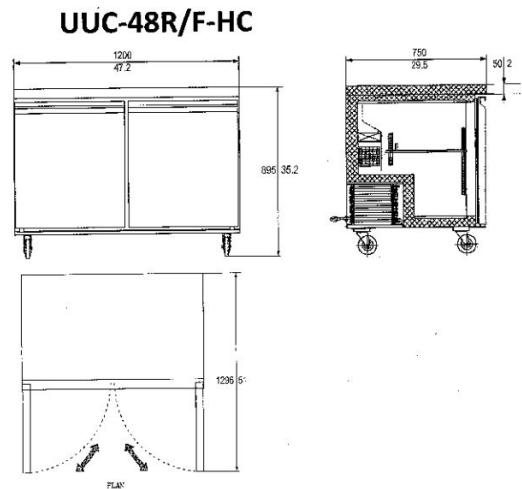

Doors	Shelves	Dimensions - LxWxD mm / in	Capacity	HP	AMPS	Voltage	Plug Type
2	2	895 / 35 1/8" 1200 / 47 1/8" 750 / 29 1/2"	12ft	1/4+	4.5	115/60/1	NEMA 5-15P

- Stainless steel interior and exterior sides, aluminum back.
- Refrigeration system keeps food at safe temperatures between -22°C to -18°C
- Features a self-closing and stay-open locking door
- Includes 3 epoxy coated shelves with 90 lb. capacity each
- Digital temperature controller with automatic defrost function
- Preinstalled heavy duty casters with brakes
- Eco-friendly & efficient Hydro-Carbon R290 refrigerant



KUC-F Series - Undercounter Freezers

KUC60-F-2



UUC-60R/F-HC

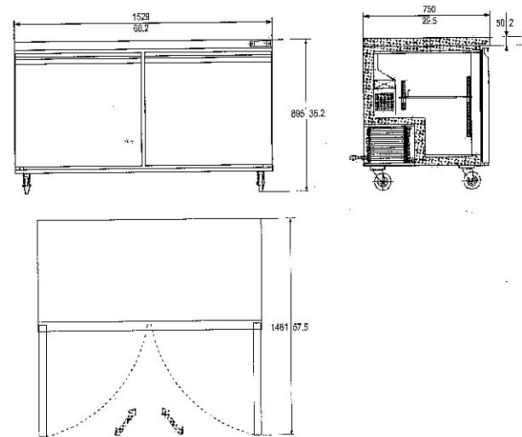

Doors	Shelves	Dimensions - LxWxD mm / in	Capacity	HP	AMPS	Voltage	Plug Type
2	2	895 / 35 1/8" 1526 / 60 1/8" 750 / 29 1/2"	15ft	1/2+	6.36	115/60/1	NEMA 5-15P

- Stainless steel interior and exterior sides, aluminum back.
- Refrigeration system keeps food at safe temperatures between -22°C to -18°C
- Features a self-closing and stay-open locking door
- Includes 3 epoxy coated shelves with 90 lb. capacity each
- Digital temperature controller with automatic defrost function
- Preinstalled heavy duty casters with brakes
- Eco-friendly & efficient Hydro-Carbon R290 refrigerant



KWT Series - Worktop Refrigerators

KWT-27R-2



UUC-27R/F-HC

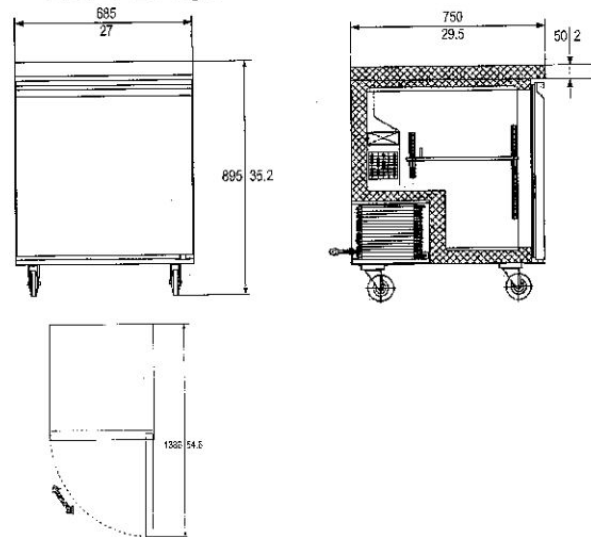

Doors	Shelves	Dimensions - LxWxD mm / in	Capacity	HP	AMPS	Voltage	Plug Type
1	1	984 / 38 3/4" 685 / 27" 750 / 29 1/2"	6.3ft	1/6	1.9	115/60/1	NEMA 5-15P

- Stainless steel interior and exterior sides, aluminum back.
- Refrigeration system keeps food at safe temperatures between 0.5°C to 5°C
- Features a self-closing and stay-open locking door
- Includes 3 epoxy coated shelves with 90 lb. capacity each
- Digital temperature controller with automatic defrost function
- Preinstalled heavy duty casters with brakes
- Eco-friendly & efficient Hydro-Carbon R290 refrigerant



KWT Series - Worktop Refrigerators

KWT-48R-2



UUC-48R/F-HC

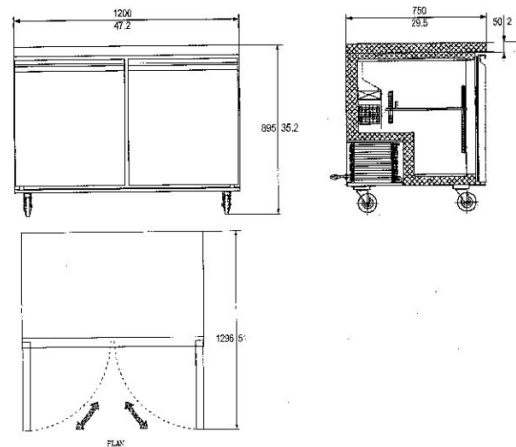

Doors	Shelves	Dimensions - LxWxD mm / in	Capacity	HP	AMPS	Voltage	Plug Type
2	2	984 / 38 3/4" 1200 / 47 1/8" 750 / 29 1/2"	12ft	1/5	2.7	115/60/1	NEMA 5-15P

- Stainless steel interior and exterior sides, aluminum back.
- Refrigeration system keeps food at safe temperatures between 0.5°C to 5°C
- Features a self-closing and stay-open locking door
- Includes 3 epoxy coated shelves with 90 lb. capacity each
- Digital temperature controller with automatic defrost function
- Preinstalled heavy duty casters with brakes
- Eco-friendly & efficient Hydro-Carbon R290 refrigerant



KWT Series - Worktop Refrigerators

KWT-60R-2



UUC-60R/F-HC

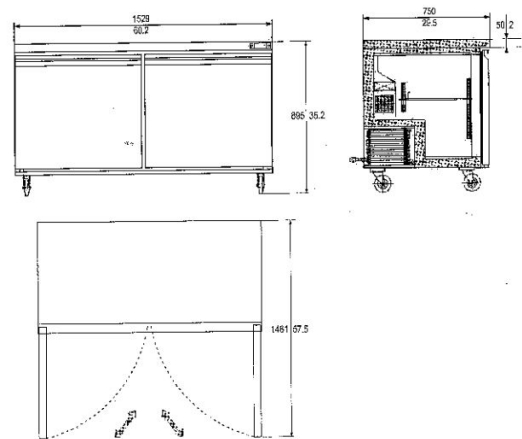

Doors	Shelves	Dimensions - LxWxD mm / in	Capacity	HP	AMPS	Voltage	Plug Type
2	2	984 / 38 3/4" 1526 / 60 1/8" 750 / 29 1/8"	15ft	1/5	2.9	115/60/1	NEMA 5-15P

- Stainless steel interior and exterior sides, aluminum back.
- Refrigeration system keeps food at safe temperatures between 0.5°C to 5°C
- Features a self-closing and stay-open locking door
- Includes 3 epoxy coated shelves with 90 lb. capacity each
- Digital temperature controller with automatic defrost function
- Preinstalled heavy duty casters with brakes
- Eco-friendly & efficient Hydro-Carbon R290 refrigerant



KWT Series - Worktop Refrigerators

KWT-72R-3



UUC-72R-HC

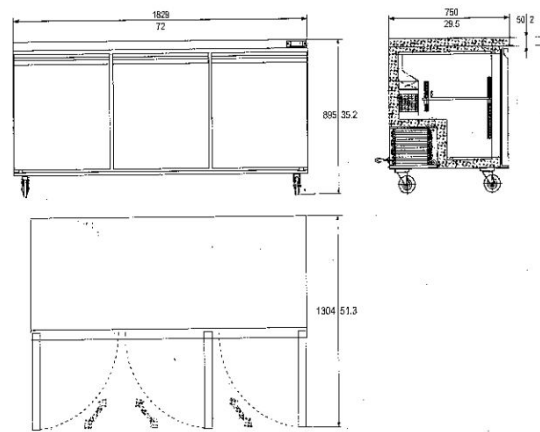

Doors	Shelves	Dimensions - LxWxD mm / in	Capacity	HP	AMPS	Voltage	Plug Type
3	3	984 / 38 3/4" 1829 / 72" 750 / 29 1/2"	15.5ft	1/5	3.2	115/60/1	NEMA 5-15P

- Stainless steel interior and exterior sides, aluminum back.
- Refrigeration system keeps food at safe temperatures between 0.5°C to 5°C
- Features a self-closing and stay-open locking door
- Includes 3 epoxy coated shelves with 90 lb. capacity each
- Digital temperature controller with automatic defrost function
- Preinstalled heavy duty casters with brakes
- Eco-friendly & efficient Hydro-Carbon R290 refrigerant



KWT-F Series - Worktop Freezers

KWT-27F-1



UUC-27R/F-HC

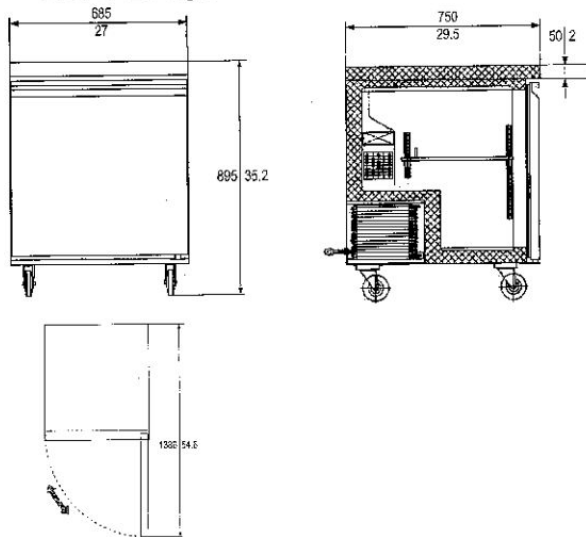

Doors	Shelves	Dimensions - LxWxD mm / in	Capacity	HP	AMPS	Voltage	Plug Type
1	1	984 / 38 3/4" 685 / 27" 750 / 29 1/2"	6.3ft	1/5	2.1	115/60/1	NEMA 5-15P

- Stainless steel interior and exterior sides, aluminum back.
- Refrigeration system keeps food at safe temperatures between -22°C to -18°C
- Features a self-closing and stay-open locking door
- Includes 3 epoxy coated shelves with 90 lb. capacity each
- Digital temperature controller with automatic defrost function
- Preinstalled heavy duty casters with brakes
- Eco-friendly & efficient Hydro-Carbon R290 refrigerant



KWT-F Series - Worktop Freezers

KWT-48F-2



UUC-48R/F-HC

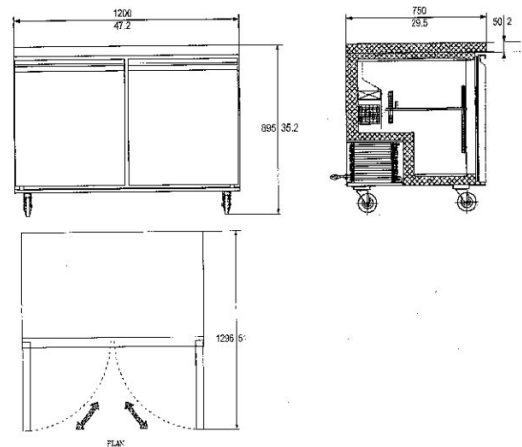

Doors	Shelves	Dimensions - LxWxD mm / in	Capacity	HP	AMPS	Voltage	Plug Type
2	2	984 / 38 3/4" 1200 / 47 1/8" 750 / 29 1/2"	12ft	1/4+	4.5	115/60/1	NEMA 5-15P

- Stainless steel interior and exterior sides, aluminum back.
- Refrigeration system keeps food at safe temperatures between -22°C to -18°C
- Features a self-closing and stay-open locking door
- Includes 3 epoxy coated shelves with 90 lb. capacity each
- Digital temperature controller with automatic defrost function
- Preinstalled heavy duty casters with brakes
- Eco-friendly & efficient Hydro-Carbon R290 refrigerant



KWT-F Series - Worktop Freezers

KWT-60F-2



UUC-60R/F-HC

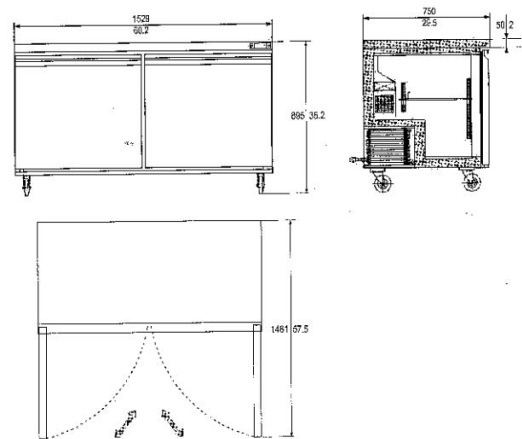

Doors	Shelves	Dimensions - LxWxD mm / in	Capacity	HP	AMPS	Voltage	Plug Type
2	2	984 / 38 3/4" 1526 / 60 1/8" 750 / 29 1/2"	15ft	1/2+	6.36	115/60/1	NEMA 5-15P

- Stainless steel interior and exterior sides, aluminum back.
- Refrigeration system keeps food at safe temperatures between -22°C to -18°C
- Features a self-closing and stay-open locking door
- Includes 3 epoxy coated shelves with 90 lb. capacity each
- Digital temperature controller with automatic defrost function
- Preinstalled heavy duty casters with brakes
- Eco-friendly & efficient Hydro-Carbon R290 refrigerant

