

KMC Series - Merchandising Swing Glass Door Refrigerators

KMC-10G

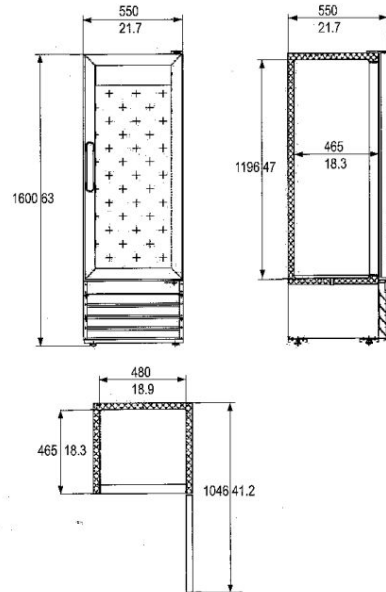

Doors	Shelves	Dimensions - LxWxD mm / in	Capacity	HP	AMPS	Voltage	Plug Type
1	4	1600 / 63" 550 / 21 5/8" 550 / 21 5/8"	9.1ft	1/5	2.88	115/60/1	NEMA 5-15P

- Stainless steel interior and exterior sides, aluminum back.
- Refrigeration system keeps food at safe temperatures between 0.5°C to 5°C
- Features a self-closing and stay-open locking door
- Includes 3 epoxy coated shelves with 90 lb. capacity each
- Digital temperature controller with automatic defrost function
- Preinstalled heavy duty casters with brakes
- Eco-friendly & efficient Hydro-Carbon R290 refrigerant



GBMF Series - Merchandising Swing Glass Door Refrigerators

KMC-12G

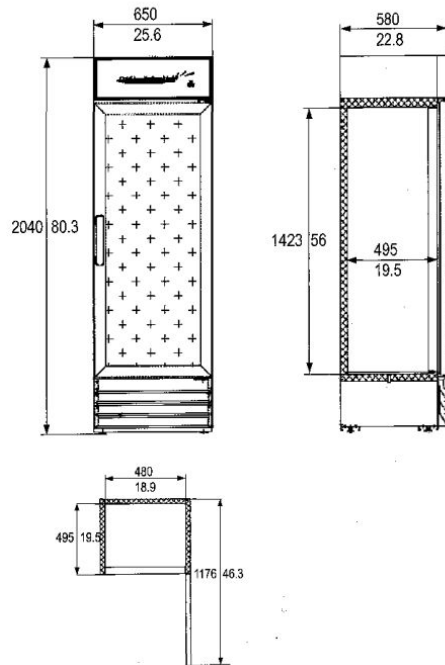

Doors	Shelves	Dimensions - LxWxD mm / in	Capacity	HP	AMPS	Voltage	Plug Type
1	4	2040 / 80 3/8" 660 / 26" 650 / 25 5/8"	13ft	1/5	2.88	115/60/1	NEMA 5-15P

- Stainless steel interior and exterior sides, aluminum back.
- Refrigeration system keeps food at safe temperatures between 0.5°C to 5°C
- Features a self-closing and stay-open locking door
- Includes 3 epoxy coated shelves with 90 lb. capacity each
- Digital temperature controller with automatic defrost function
- Preinstalled heavy duty casters with brakes
- Eco-friendly & efficient Hydro-Carbon R290 refrigerant



GBMF Series - Merchandising Swing Glass Door Refrigerators

KMC-15G

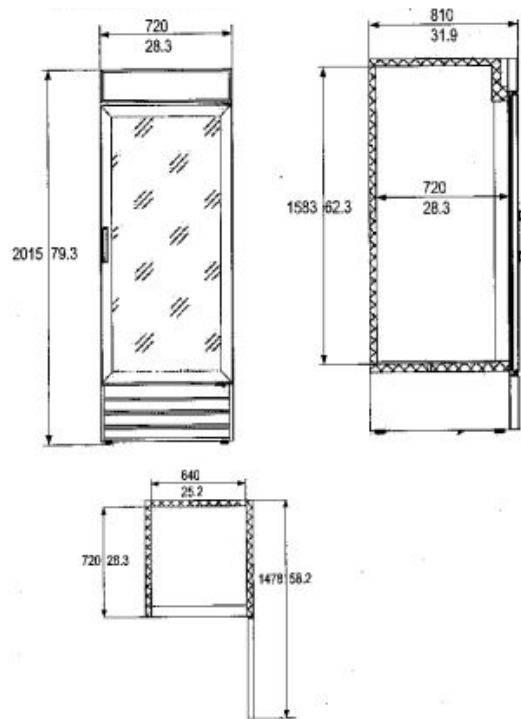

Doors	Shelves	Dimensions - LxWxD mm / in	Capacity	HP	AMPS	Voltage	Plug Type
1	4	2015 / 79 ³ / ₈ " 650 / 25 ³ / ₈ " 580 / 22 ¹ / ₂ "	14ft	1/5	2.88	115/60/1	NEMA 5-15P

- Stainless steel interior and exterior sides, aluminum back.
- Refrigeration system keeps food at safe temperatures between 0.5°C to 5°C
- Features a self-closing and stay-open locking door
- Includes 3 epoxy coated shelves with 90 lb. capacity each
- Digital temperature controller with automatic defrost function
- Preinstalled heavy duty casters with brakes
- Eco-friendly & efficient Hydro-Carbon R290 refrigerant



KMC-SLIDING Series - Merchandising Sliding Glass Door Refrigerators

KMC-40G-SLIDING

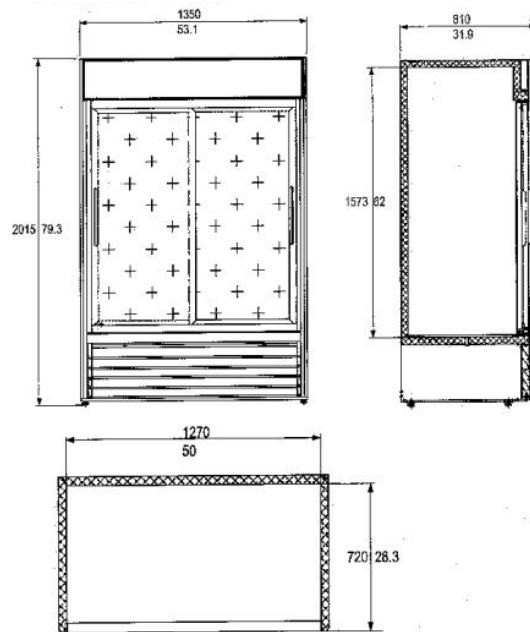

Doors	Shelves	Dimensions - LxWxD mm / in	Capacity	HP	AMPS	Voltage	Plug Type
2	8	2015 / 79 ³ / ₄ " 1350 / 53 ¹ / ₈ " 810 / 31 ⁷ / ₈ "	45ft	1/4+	4.3	115/60/1	NEMA 5-15P

- Stainless steel interior and exterior sides, aluminum back.
- Refrigeration system keeps food at safe temperatures between 0.5°C to 5°C
- Features a self-closing double pane glass door with positive seal
- Includes 3 epoxy coated shelves with 90 lb. capacity each
- Digital temperature controller with automatic defrost function
- Preinstalled heavy duty casters with brakes
- Eco-friendly & efficient Hydro-Carbon R290 refrigerant



KMC Series - Merchandising Swing Glass Door Refrigerators

KMC-48G-R

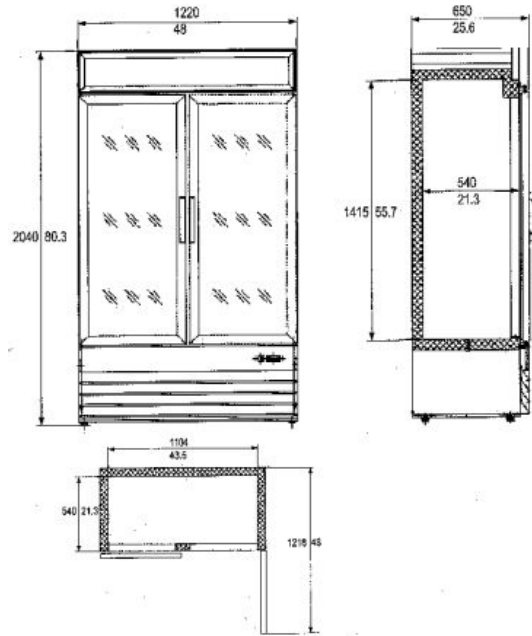

Doors	Shelves	Dimensions - LxWxD mm / in	Capacity	HP	AMPS	Voltage	Plug Type
2	8	2040 / 80 ³ / ₈ " 1220 / 48" 650 / 25 ⁵ / ₈ "	29ft	1/4+	4.8	115/60/1	NEMA 5-15P

- Stainless steel interior and exterior sides, aluminum back.
- Refrigeration system keeps food at safe temperatures between 0.5°C to 5°C
- Features a self-closing and stay-open locking door
- Includes 3 epoxy coated shelves with 90 lb. capacity each
- Digital temperature controller with automatic defrost function
- Preinstalled heavy duty casters with brakes
- Eco-friendly & efficient Hydro-Carbon R290 refrigerant



KMC Series - Merchandising Swing Glass Door Refrigerators

KMC-54G-R

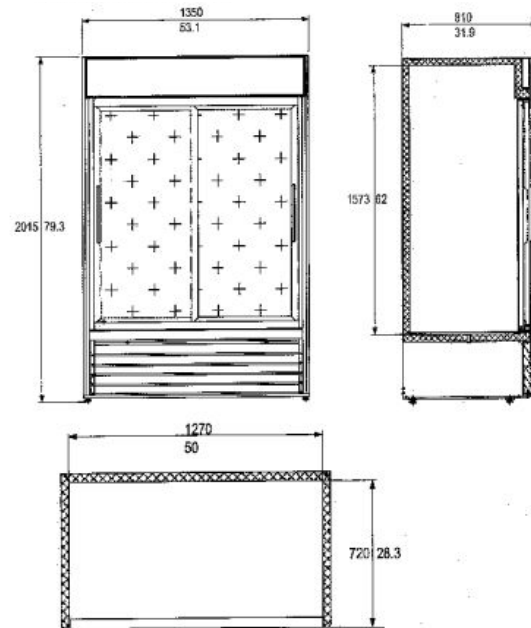

Doors	Shelves	Dimensions - LxWxD mm / in	Capacity	HP	AMPS	Voltage	Plug Type
2	8	2015 / 79 3/8" 1350 / 53 1/8" 810 / 31 7/8"	45ft	1/4+	4.3	115/60/1	NEMA 5-15P

- Stainless steel interior and exterior sides, aluminum back.
- Refrigeration system keeps food at safe temperatures between 0.5°C to 5°C
- Features a self-closing and stay-open locking door
- Includes 3 epoxy coated shelves with 90 lb. capacity each
- Digital temperature controller with automatic defrost function
- Preinstalled heavy duty casters with brakes
- Eco-friendly & efficient Hydro-Carbon R290 refrigerant



KMC Series - Merchandising Swing Glass Door Refrigerators

KMC-79G-R

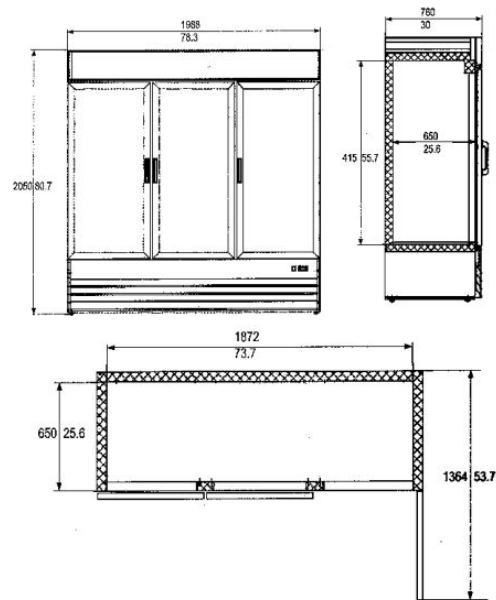

Doors	Shelves	Dimensions - LxWxD mm / in	Capacity	HP	AMPS	Voltage	Plug Type
3	12	2050 / 80 ³ / ₄ " 1988 / 78 ³ / ₈ " 760 / 30"	45ft	1/4+	4.3	115/60/1	NEMA 5-15P

- Stainless steel interior and exterior sides, aluminum back.
- Refrigeration system keeps food at safe temperatures between 0.5°C to 5°C
- Features a self-closing and stay-open locking door
- Includes 3 epoxy coated shelves with 90 lb. capacity each
- Digital temperature controller with automatic defrost function
- Preinstalled heavy duty casters with brakes
- Eco-friendly & efficient Hydro-Carbon R290 refrigerant



KMC-F Series - Merchandising Swing Glass Door Freezers

KMC-10G-F

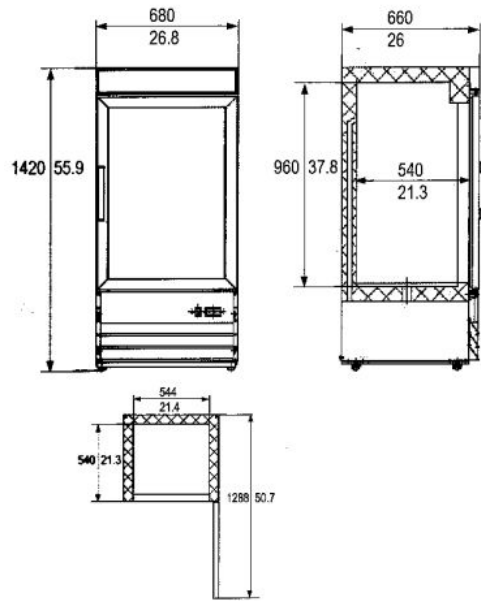

Doors	Shelves	Dimensions - LxWxD mm / in	Capacity	HP	AMPS	Voltage	Plug Type
1	2	1420 / 55 7/8" 680 / 26 5/8" 660 / 26"	8.5ft	1/4+	3.5	115/60/1	NEMA 5-15P

- Stainless steel interior and exterior sides, aluminum back.
- Refrigeration system keeps food at safe temperatures between -23°C to -18°C
- Features a self-closing and stay-open locking door
- Includes 3 epoxy coated shelves with 90 lb. capacity each
- Digital temperature controller with automatic defrost function
- Preinstalled heavy duty casters with brakes
- Eco-friendly & efficient Hydro-Carbon R290 refrigerant



KMC-F Series - Merchandising Swing Glass Door Freezers

KMC-12G-F

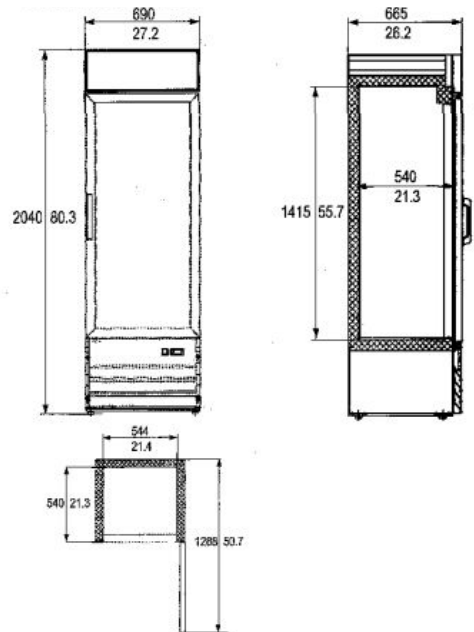

Doors	Shelves	Dimensions - LxWxD mm / in	Capacity	HP	AMPS	Voltage	Plug Type
1	4	2040 / 80 ³ / ₈ " 690 / 27 ¹ / ₂ " 665 / 26 ¹ / ₂ "	13ft	3/4	8.8	115/60/1	NEMA 5-15P

- Stainless steel interior and exterior sides, aluminum back.
- Refrigeration system keeps food at safe temperatures between -23°C to -18°C
- Features a self-closing and stay-open locking door
- Includes 3 epoxy coated shelves with 90 lb. capacity each
- Digital temperature controller with automatic defrost function
- Preinstalled heavy duty casters with brakes
- Eco-friendly & efficient Hydro-Carbon R290 refrigerant



KBMF Series - Merchandising Swing Glass Door Freezers

KMC-15G-F

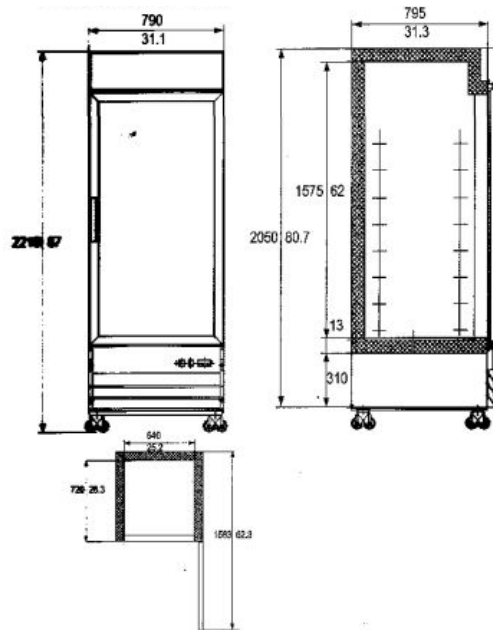

Doors	Shelves	Dimensions - LxWxD mm / in	Capacity	HP	AMPS	Voltage	Plug Type
1	4	2050 / 80 ³ / ₄ " 790 / 31 ¹ / ₈ " 795 / 31 ³ / ₈ "	23ft	3/4	9.4	115/60/1	NEMA 5-15P

- Stainless steel interior and exterior sides, aluminum back.
- Refrigeration system keeps food at safe temperatures between -23°C to -18°C
- Features a self-closing and stay-open locking door
- Includes 3 epoxy coated shelves with 90 lb. capacity each
- Digital temperature controller with automatic defrost function
- Preinstalled heavy duty casters with brakes
- Eco-friendly & efficient Hydro-Carbon R290 refrigerant



KMC-F Series - Merchandising Swing Glass Door Freezers

KMC-48G-F

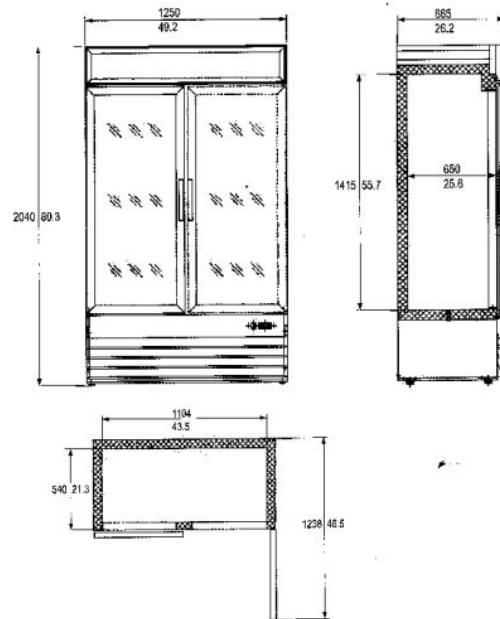

Doors	Shelves	Dimensions - LxWxD mm / in	Capacity	HP	AMPS	Voltage	Plug Type
2	8	2040 / 80 ³ / ₈ " 1250 / 49 ¹ / ₈ " 665 / 26 ¹ / ₈ "	29ft	3/4	9.4	115/60/1	NEMA 5-15P

- Stainless steel interior and exterior sides, aluminum back.
- Refrigeration system keeps food at safe temperatures between -23°C to -18°C
- Features a self-closing and stay-open locking door
- Includes 3 epoxy coated shelves with 90 lb. capacity each
- Digital temperature controller with automatic defrost function
- Preinstalled heavy duty casters with brakes
- Eco-friendly & efficient Hydro-Carbon R290 refrigerant



KBMF Series - Merchandising Swing Glass Door Freezers

KMC-54G-F

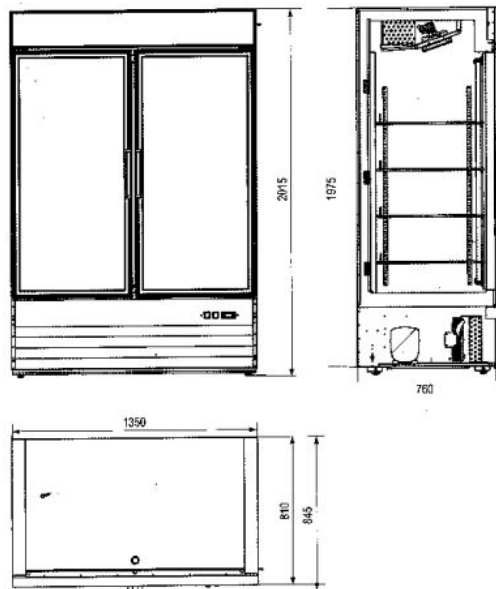

Doors	Shelves	Dimensions - LxWxD mm / in	Capacity	HP	AMPS	Voltage	Plug Type
2	8	2015 / 79 ³ / ₈ " 1350 / 53 ¹ / ₈ " 810 / 31 ⁷ / ₈ "	45ft	1	9.2	115/60/1	NEMA 5-15P

- Stainless steel interior and exterior sides, aluminum back.
- Refrigeration system keeps food at safe temperatures between -23°C to -18°C
- Features a self-closing and stay-open locking door
- Includes 3 epoxy coated shelves with 90 lb. capacity each
- Digital temperature controller with automatic defrost function
- Preinstalled heavy duty casters with brakes
- Eco-friendly & efficient Hydro-Carbon R290 refrigerant



KBMF Series - Merchandising Swing Glass Door Freezers

KMC-79G-F

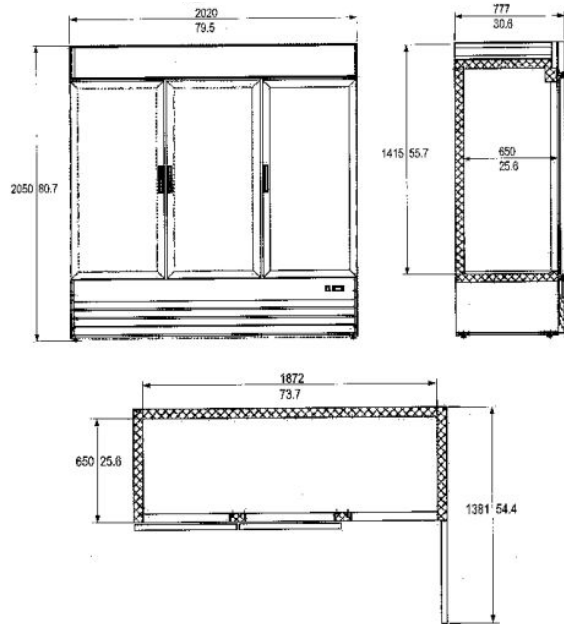

Doors	Shelves	Dimensions - LxWxD mm / in	Capacity	HP	AMPS	Voltage	Plug Type
3	12	2050 / 80 ³ / ₄ " 2020 / 79 ¹ / ₂ " 777 / 30 ³ / ₈ "	52ft	0.75 * 2	16.3	115/60/1	NEMA 5-15P

- Stainless steel interior and exterior sides, aluminum back.
- Refrigeration system keeps food at safe temperatures between -23°C to -18°C
- Features a self-closing and stay-open locking door
- Includes 3 epoxy coated shelves with 90 lb. capacity each
- Digital temperature controller with automatic defrost function
- Preinstalled heavy duty casters with brakes
- Eco-friendly & efficient Hydro-Carbon R290 refrigerant

